



Big Dutchman®



Air Master

V-belt driven fans with a high air flow rate
and low energy consumption

AIR MASTER – the durable high-performance fan

The newly developed **AIR MASTER** available from Big Dutchman is an all-purpose fan which stands out due to its performance capacity, low energy and maintenance requirements, robustness and corrosion resistance.

The following types of AIR MASTER are available:

- 3 or 5 blades;
- speed-controlled (transformer/frequency converter);

- with or without cone;
- mounted or unmounted.

Let our experts advise you to find the best possible solution for your building!

Advantages

- optimised aerodynamics at the air admission and air exit sides for a high air flow rate;
- specially-formed blades ensure optimum operation for lower energy costs;
- the shutters open by airflow pressure; they stay open thanks to balancing weights, thus there is minimal air resistance;
- low noise level;
- stable, robust and simple construction;
- the approach flow nozzle and blades are made of polypropylene for high corrosion resistance and a long service life;
- the fan is easy-to-assemble and easy to install in the building.



Important component parts

1. Casing

The fan casing consists of galvanized sheet steel, the inside construction is made of high-quality polypropylene for high corrosion resistance.

2. Blades and blade hub

The vane has 3 or 5 specially shaped blades made of glass fibre reinforced plastic. Air guide-rails on every blade ensure a large air flow rate combined with a low resistance and thus low energy consumption. The blade hub is made of aluminium.

The 5-blade AIR MASTER is used in cases of high back pressure (cage systems with tunnel ventilation, use of exhaust air treatment systems).

3. Shutters

The shutters are opened by the air flow and then kept open by means of a balancing weight. When the ventilator stops, the shutters close. Thus it is not necessary to install a costly mechanical centrifugal system.

4. V-belt gearing

The V-belt pulley is made of aluminium and is manufactured as one piece together with the blade hub, by diecasting. The V-belt is prestressed, further tensioning is therefore not necessary.

5. Electric motors

A top-quality motor with a large voltage range is used. The motor is completely closed; a separate cooling fan is not necessary. Thus there is no danger of dust entering the motor or overheating the motor.

6. Cone

Cone fans are mainly used in houses with even larger air flow requirements. They are also characterized by low power consumption.



Light trap

The light trap available from Big Dutchman reduces the amount of light passing through the fan to a minimum. The air throughput, however, is only slightly reduced.

The shutters of the light trap are made of plastic. Thus they are corrosion-resistant and easy to clean.

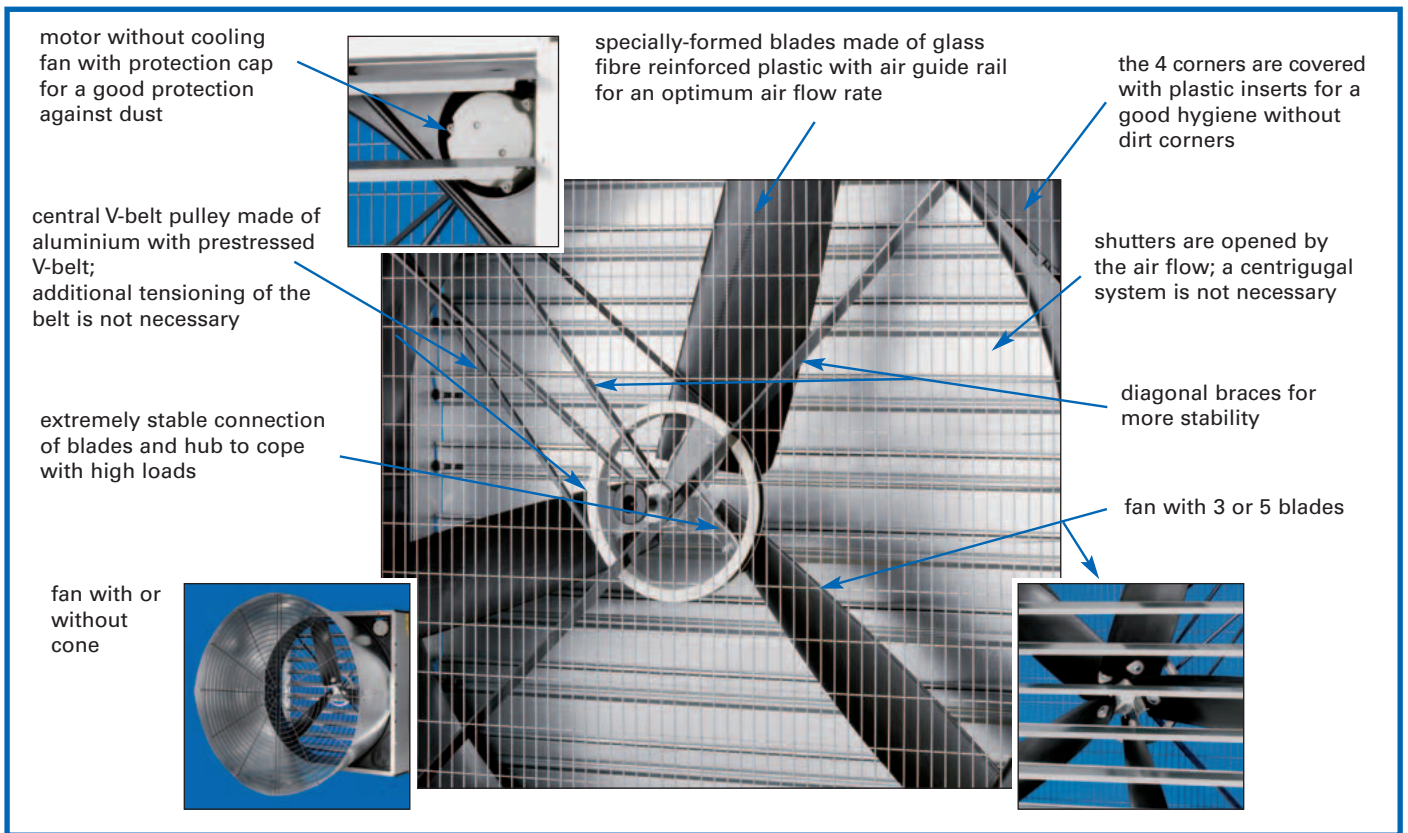

AIR MASTER – many variants for a wide range of applications

The newly developed AIR MASTER is very flexible and can be used in different climate zones. Longitudinal, gable-, tunnel or CombiTunnel ventilation are some of the possible ventilation concepts.

In case of longitudinal or gable ventilation, the AIR MASTER sucks the air through the length of the house. In case of decentralized exhaust air extraction, the AIR MASTER can be activated in addition to the extra ventilation in the gables on very hot summer days.

In case of tunnel ventilation, they suck the air through the length of the house at a high speed. This provides replacement ventilation with a minimum power consumption.

CombiTunnel ventilation is the right system if the climate involves large temperature fluctuations – summer/winter or day and night temperatures.

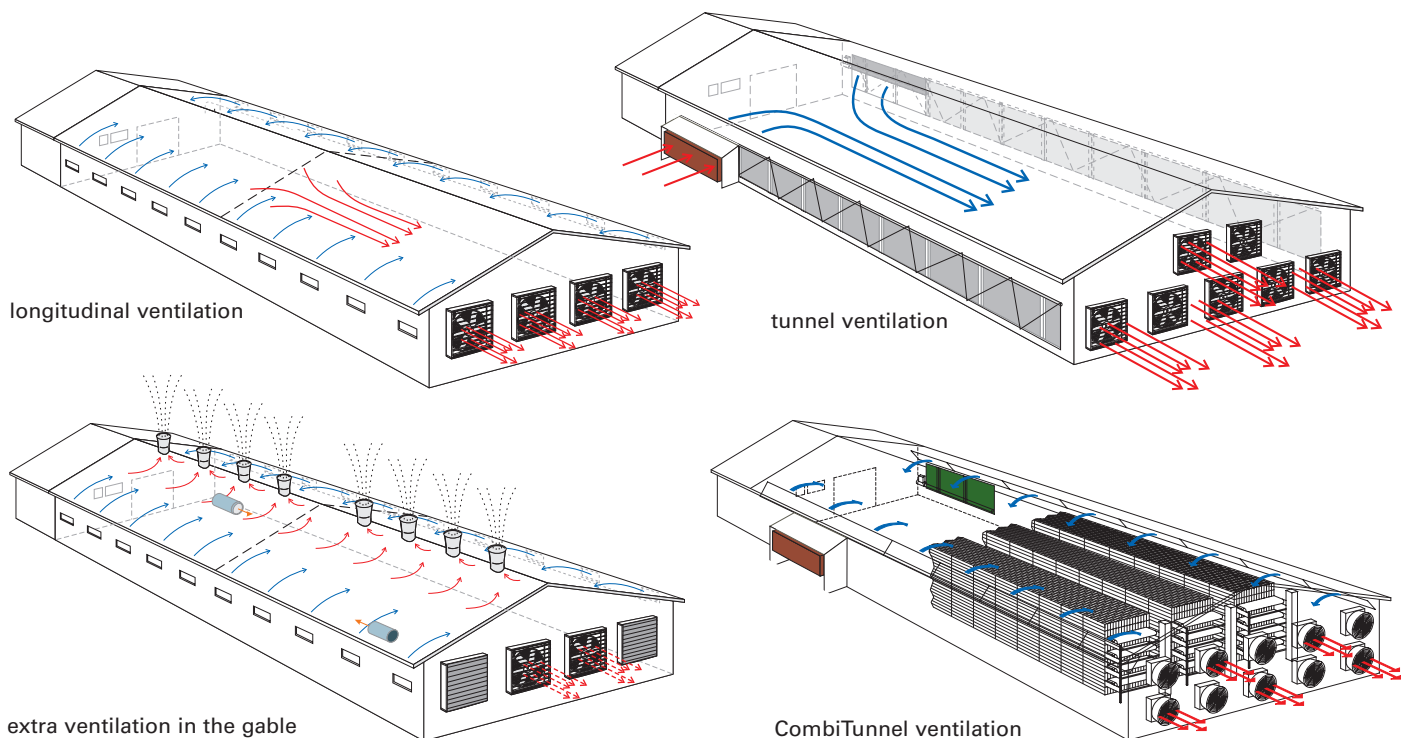

Technical specifications of the AIR MASTER type V130

Type	Code no.	Speed-control	Air rate in m ³ /h					Current consumption		spec. output (watt/1000m ³ /h)
			0 Pa	20 Pa	30 Pa	40 Pa	60 Pa	80 Pa	(ampere)	
V130-3 1,5 PS-R	60-25-4000	FC	43,700	39,700	37,500	34,800	28,600	19.200	3.1	36.7
V130-3 1,5 PS	60-25-4005	T	43,200	39,000	36,600	34,000	27,900	19.600	3.1	35.9
V130-3 1,0 PS	60-25-4004	T	39,700	35,600	32,300	29,300	21,600		2.6	30.5
VC130-3 1,5 PS-R	60-25-4020	FC	47,700	43,800	41,600	39,200	34,300	21.800	3.2	34.3
VC130-3 1,5 PS	60-25-4025	T	47,300	43,300	41,000	38,700	33,500	21.200	3.2	33.1
VC130-3 1,0 PS	60-25-4024	T	42,800	38,500	35,900	33,400	23,600		2.7	27.3
V130-5 1,5 PS-R	60-25-4040	FC	38,700	35,600	34,100	32,500	28,800	24.500	3.0	36.8
V130-5 1,5 PS	60-25-4045	T	37,900	35,300	33,800	32,200	28,300	23.900	3.0	35.5
VC130-5 1,5 PS-R	60-25-4060	FC	41,800	38,800	37,200	35,600	32,300	27.100	3.1	33.4
VC130-5 1,5 PS	60-25-4065	T	41,400	38,400	36,800	35,100	31,700	26.200	3.1	32.1

V = fan without cone; VC = fan with cone; 130 = vane diameter; 3 = 3-blade; 5 = 5-blade; R = regular motor

FC - frequency controlled drive T - transformer controlled

Connexion values: 400 V, 50 Hz; also available with one or three phase and with 60 Hz

Weight: AIR MASTER without cone: 80 kg; AIR MASTER with cone: 99 kg

All types are also available unmounted

If used in the European Union, the fans must have the CE mark of conformity. As opposed to fans without CE mark these fans possess a protective screen (in front of the shutters at an installation height below 2.70 m).

Accessories

Code no.

Specifications of the motor

mounting-flange-set

60-25-4230

motor protection class IP 55

wire mesh guard for shutter

60-25-4235

approved for UL/CSA (not for R-motor)

light trap

60-25-4240

for different voltages, frequencies and phases

Dimensions AIRMASTER V 130

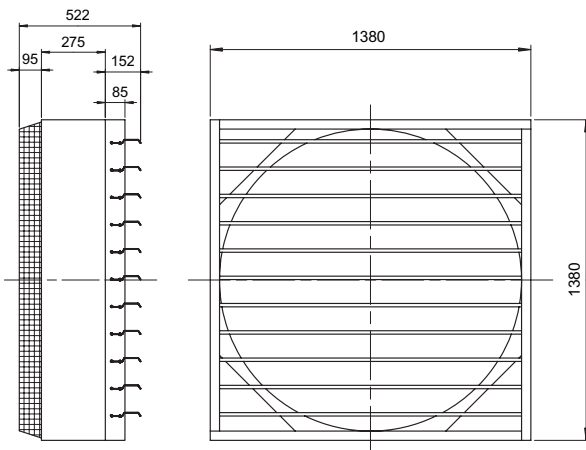

VC 130

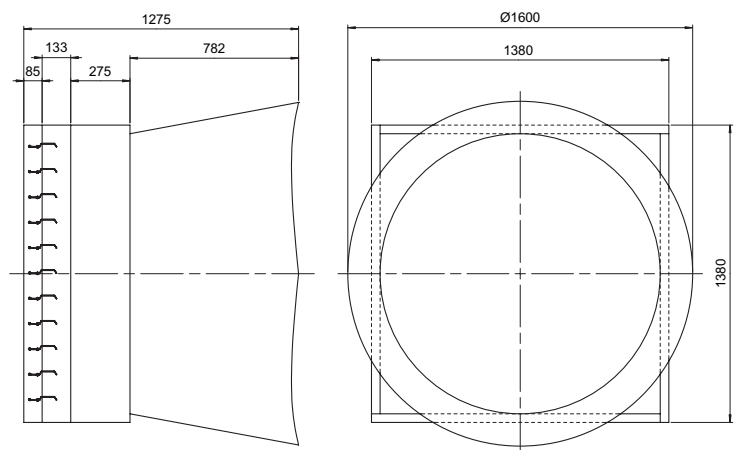

Big Dutchman.

Germany

Big Dutchman International GmbH

Big Dutchman Pig Equipment GmbH

Postfach 1163 · 49360 Vechta · Germany

Tel. +49(0)4447-801-0

Fax +49(0)4447-801-237

E-Mail: big@bigdutchman.de

Asia

BD Asia Sdn. Bhd.

No. 20, Lorong Keluli 1 B,

Kawasan Perindustrian Bukit Raja,

Seksyen 7, 40000 Shah Alam,

Selangor Darul Ehsan · Malaysia

Tel. +60-3-33 61 5555 · Fax +60-3-33 42 2866

e-mail: bdasia@bigdutchman.com

USA

Big Dutchman, Inc.

P.O. Box 1017 · Holland, MI 49422-1017 · USA

Tel. +1-616-392 59 81

Fax +1-616-392 61 88

e-mail: bigd@bigdutchmanusa.com