

POTTERS ARE LEADING SUPPLIERS OF CAGE FREE POULTRY EQUIPMENT

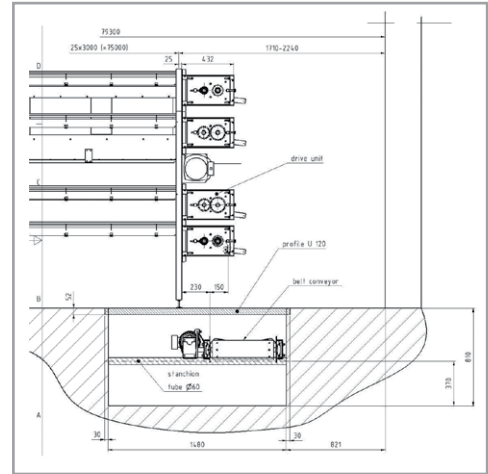

# Multi-tier aviary

## Cage free - free range



Heavy duty drive sets ensure long-term reliability

The Potters Poultry multi-tier aviary system is different. Why? It is designed by farmers to be used by farmers. It is designed with easy bird management as a priority. It is the most open system available making it better to see and manage the hens.

A fully integrated system packed with features:

- A simple support system with very little of the structure fixed to the floor - meaning easy cleaning.
- An endlessly adaptable system to suit any building.
- Lighting available on all levels to minimise floor eggs.
- Minimal distances between tiers to reduce flight requirements of hens, therefore reducing injury.
- Choice of belt numbers to suit layout design and building dimensions.
- Ideally suited to new, refurb or conversion projects.
- All necessary perching provided within the system.
- Supplied as part of a complete package to provide a turnkey project.
- Supplied by a UK company with 25 years experience with manure belts and nesting within Free Range and Barn.

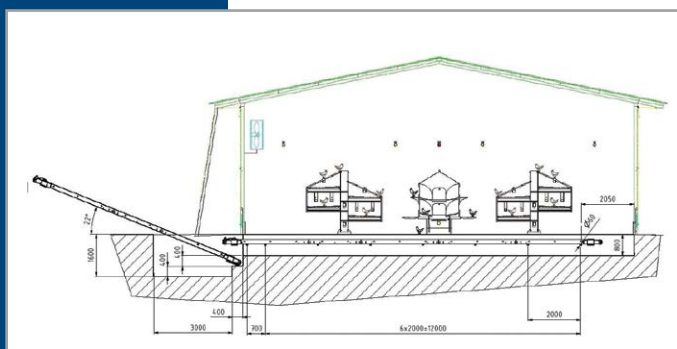

*Flexible modular systems mean any poultry house can have aviary systems installed*

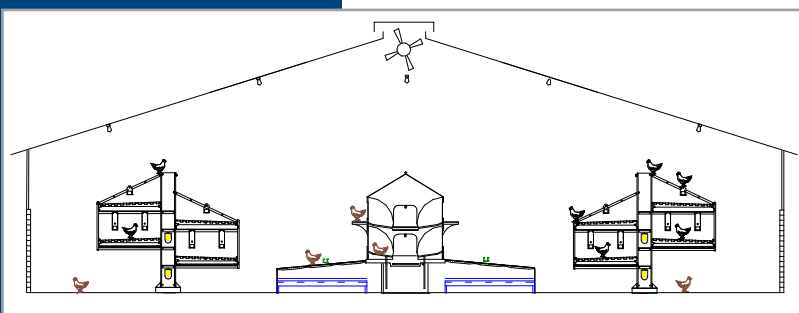
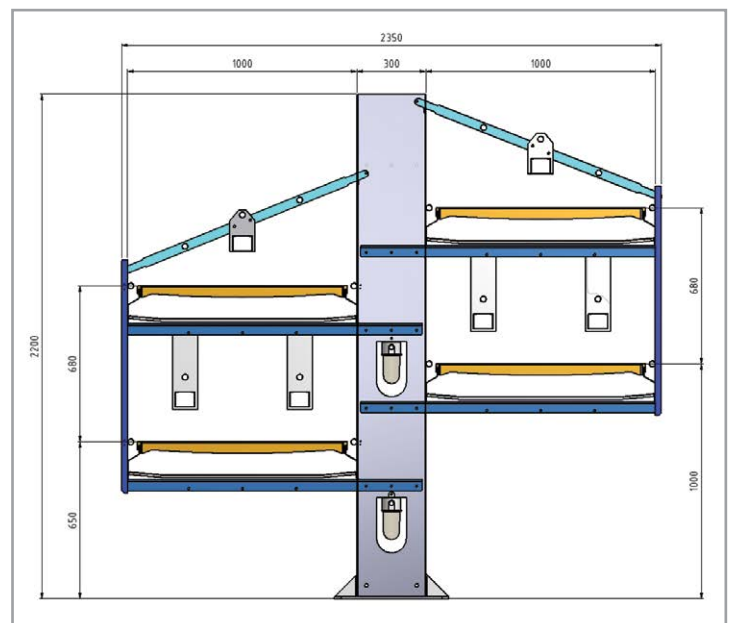
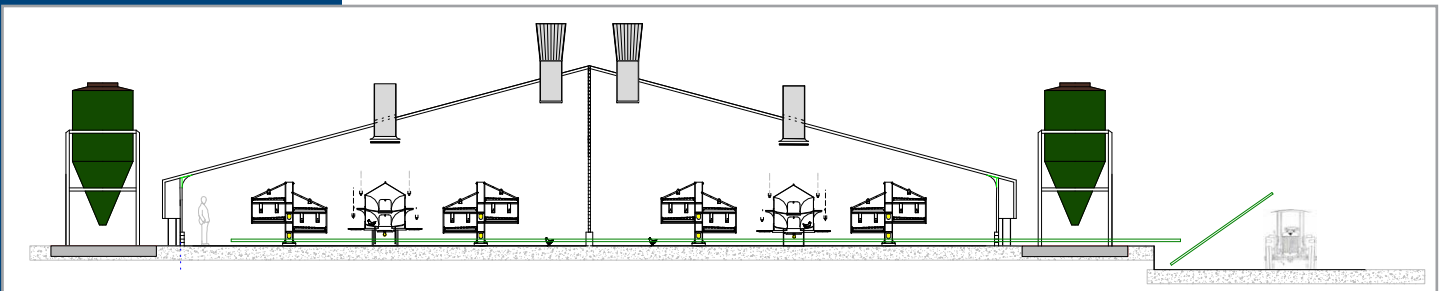
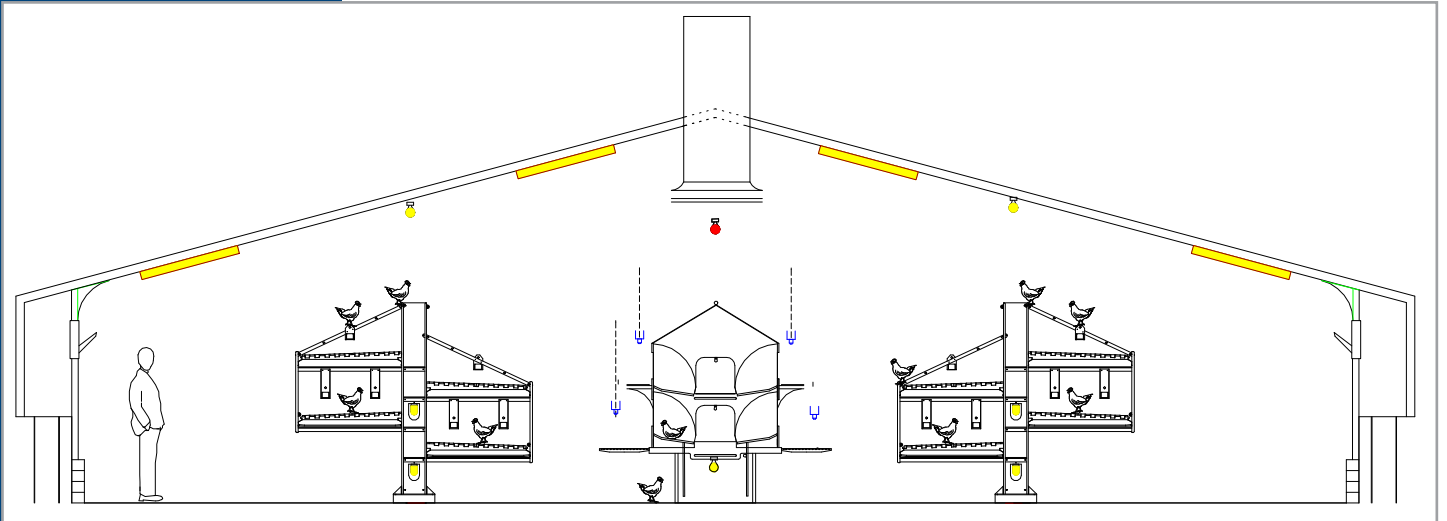

Combination design with, or without, extra manure belt.

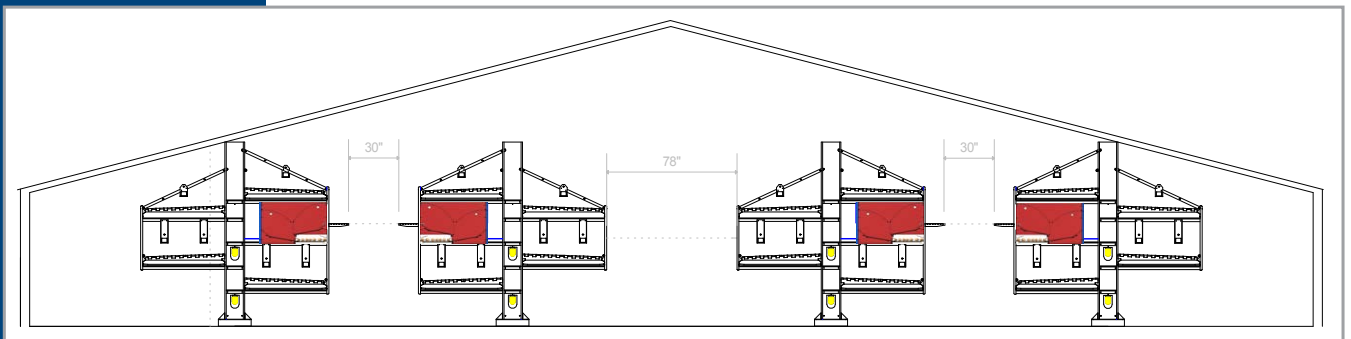
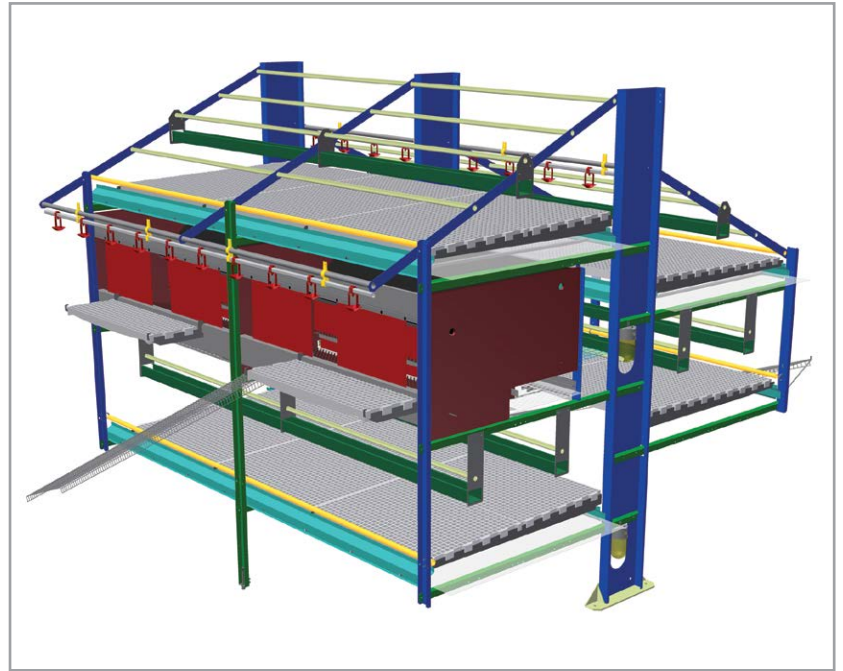

Dealer:

### Integrated Nest System

- Double sided nest, giving access from both sides
- Minimises distance birds have to travel to the nest
- Single large egg belt
- All birds visible from the floor
- Very easy management

Potters Poultry, Leigh Road, Swift Valley, Rugby CV21 1DS, United Kingdom  
 Tel: +44 (0) 1788 536161 Fax: +44 (0) 1788 579587  
[info@potterspoultry.com](mailto:info@potterspoultry.com) [www.potterspoultry.com](http://www.potterspoultry.com)